

NISSAN ALTIMA

MOTOR 2.5L QR25DE

TIMING CHAIN - CADENA DE TIEMPO

automecanico.com



TIMING CHAIN

Removal and Installation

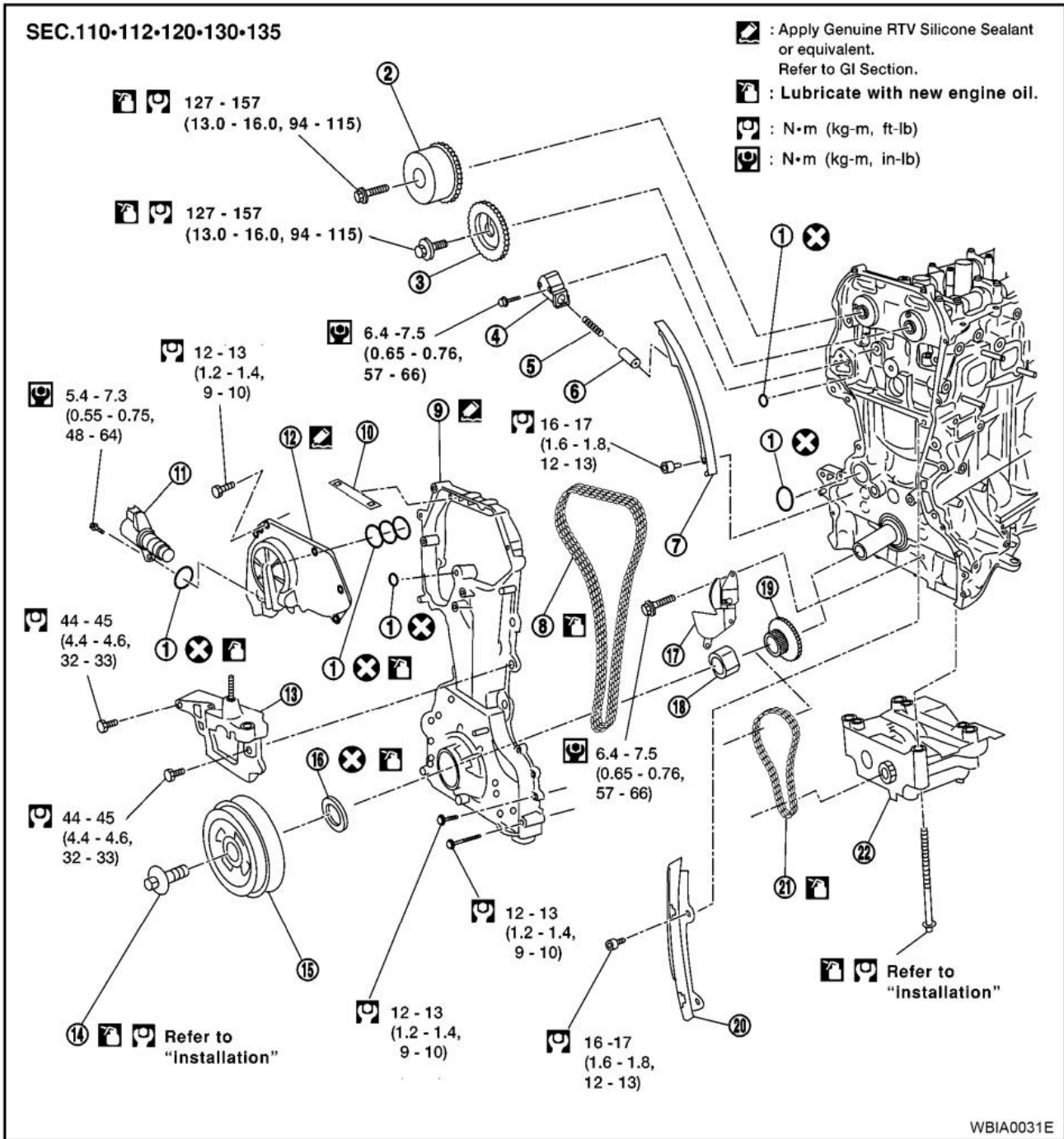

WBIA0031E

- | | | |
|-----------------------------|--|--------------------------------|
| 1. Oil rings | 2. Camshaft sprocket (INT) | 3. Camshaft sprocket (EXH) |
| 4. Chain tensioner | 5. Spring | 6. Chain tensioner plunger |
| 7. Timing chain slack guide | 8. Timing chain | 9. Front cover |
| 10. Chain guide | 11. IVTC solenoid valve | 12. IVTC cover |
| 13. Engine mounting bracket | 14. Crankshaft pulley bolt | 15. Crankshaft pulley |
| 16. Front oil seal | 17. Balancer unit timing chain tensioner | 18. Oil pump drive spacer |
| 19. Crankshaft sprocket | 20. Timing chain tension guide | 21. Balancer unit timing chain |
| 22. Balancer unit | | |

CAUTION:

Apply new engine oil to parts marked in illustration before installation.

A
EM
C
D
E
F
G
H
I
J
K
L
M

REMOVAL

1. Support the engine and transaxle assembly with suitable tools.
2. Remove the upper and lower oil pan, and oil strainer. Refer to [EM-23, "Removal and Installation"](#).
3. Remove the IVTC (intake valve timing control) cover.
 - a. Loosen bolts in the numerical order as shown.
 - b. Remove the cover with suitable tool to cut the sealant.
4. Pull chain guide between camshaft sprockets out through front cover.

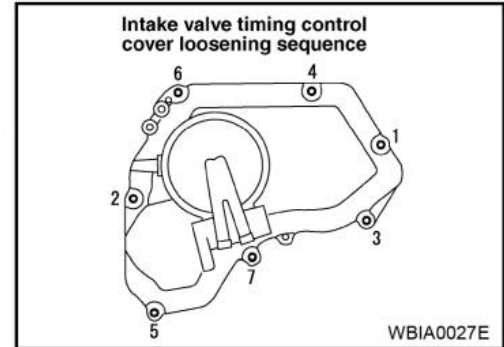

5. Set the No.1 cylinder at TDC on the compression stroke with the following procedure:
 - a. Rotate the crankshaft pulley clockwise and align the mating marks to the timing indicator on the front cover.

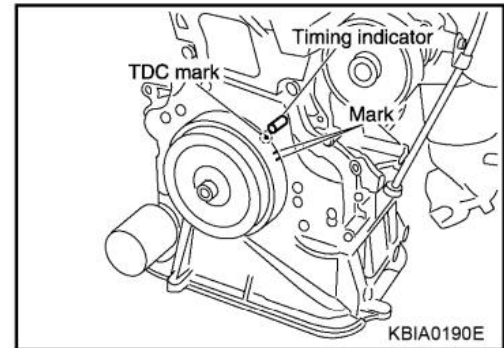

- b. At the same time, make sure that the mating marks on the camshaft sprockets are lined up as shown.
 - If not lined up, rotate the crankshaft pulley one more turn to line up the mating marks to the positions as shown.

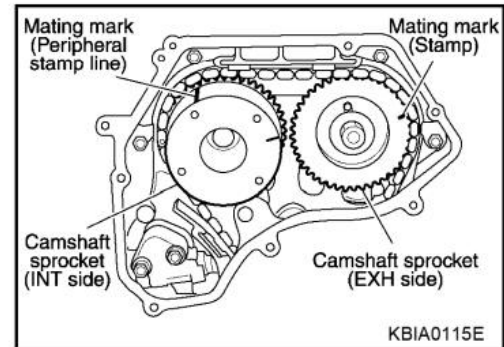

6. Remove crankshaft pulley with the following procedure:
 - a. Hold the crankshaft pulley with a suitable tool, then loosen the crankshaft pulley mounting bolt, and pull the pulley out about 10 mm (0.39 in).

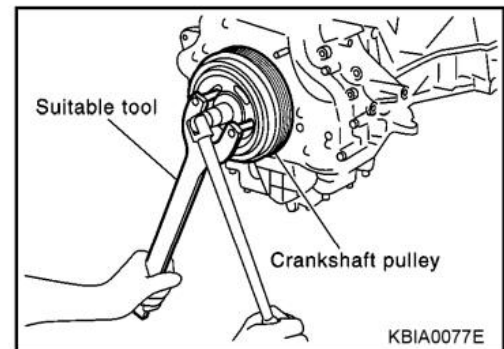

TIMING CHAIN

[QR25DE]

- b. Attach a pulley puller in the M 6 (0.24 in diameter) thread hole on crankshaft pulley, and remove crankshaft pulley.

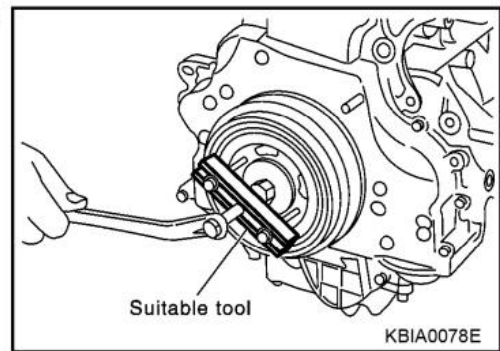

7. Remove the front cover with the following procedure:
- a. Loosen the mounting bolts in the reverse order shown in the figure, and remove them.
- b. Remove the front cover.

CAUTION:

- Be careful not to damage the mounting surface.

8. If the front oil seal needs to be replaced, lift it out with a screwdriver to remove it.

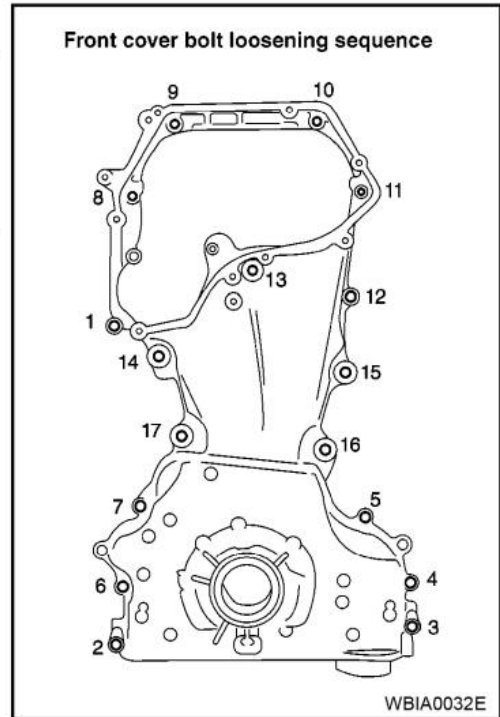

9. Remove timing chain with the following procedure:
- a. Push in the tensioner plunger. Insert a stopper pin into the hole on the tensioner body to hold the chain tensioner.
- Use a wire of 0.5 mm (0.02 in) diameter as a stopper pin.
- b. Remove the chain tensioner.

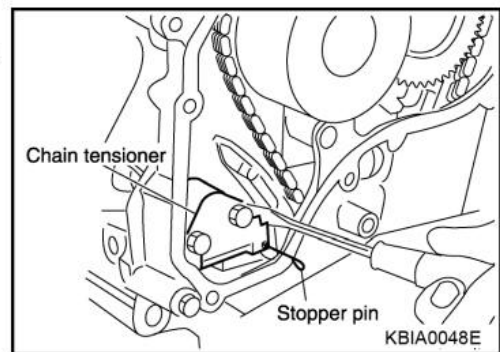

A
EM
C
D
E
F
G
H
I
J
K
L
M

TIMING CHAIN

[QR25DE]

- c. Secure hexagonal part of the camshaft with a wrench and loosen the camshaft sprocket mounting bolt and remove the camshaft sprocket for both camshafts.

CAUTION:

- Do not rotate the crankshaft or camshafts while the timing chain is removed. It can cause damage to the valve and piston.

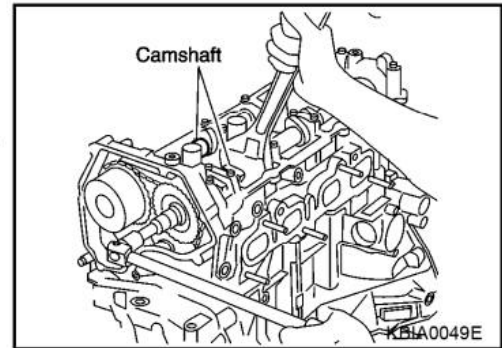

10. Remove the chain slack guide, tension guide, timing chain, and oil pump drive spacer.

11. Remove the timing chain tensioner for the balancer unit with the following procedure:

- Lift the tensioner lever up, and release the ratchet claw for installation.
- Push tensioner sleeve in, and hold it.
- Matching the hole on lever with the one on body, insert a stopper pin to secure tensioner sleeve.
- Remove the timing chain tensioner for the balancer unit.

12. Remove timing chain for balancer unit and crankshaft sprocket.

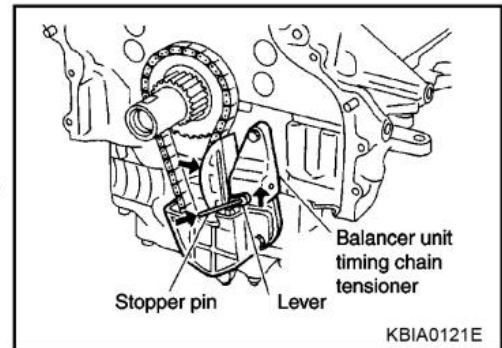

13. Loosen mounting bolts in reverse order shown in the figure, and remove balancer unit.

- Use Torx socket (size E14)

CAUTION:

- Do not disassemble balancer unit.

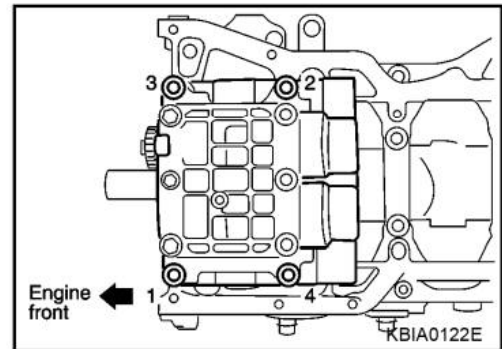

INSPECTION AFTER REMOVAL

Timing Chain

Check the timing chain for cracks or serious wear. If a defect is detected, replace it.

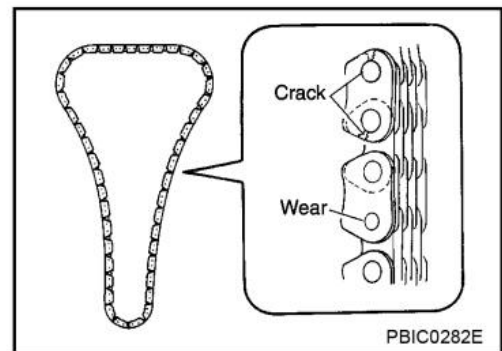

Balancer Unit Mounting Bolt Outer Diameter

- Measure outer diameters (d1, d2) at the two positions shown in the figure.
- Measure d2 within the range A.
- If the value difference (d1 - d2) exceeds the limit (a dimension difference is large), replace it with a new one.

Limit : 0.15 mm (0.0059 in) or more

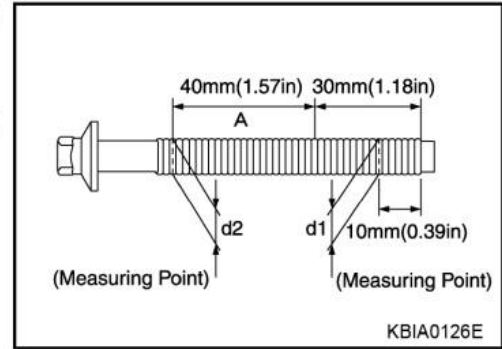

INSTALLATION

NOTE:

- There may be two color variations of the link marks (link colors) on the timing chain.
- There are 26 links between the gold/yellow mating marks on the timing chain; and 64 links between the camshaft sprocket gold/yellow link and the crankshaft sprocket orange/blue link, on the timing chain side without the tensioner.

1. Make sure the crankshaft key points straight up.
2. Install the balancer unit and tighten the mounting bolts in the numerical order shown with the following procedure:

CAUTION:

- **When reusing a mounting bolt, check its outer diameter before installation. Refer to [EM-49, "Balancer Unit Mounting Bolt Outer Diameter"](#).**

- a. Apply new engine oil to threads and seating surfaces of mounting bolts.
- b. Tighten them to 45.2 - 51.0 N·m (4.6 - 5.2 kg-m, 34 - 37 ft-lb).
- c. Turn them another 90° - 95° degrees (Target: 90° degrees).
- d. Fully loosen in the reverse order of tightening to 0 N·m (0 kg-m, 0 ft-lb).
- e. Tighten them to 45.2 - 51.0 N·m (4.6 - 5.2 kg-m, 34 - 37 ft-lb).
- f. Turn them another 90° - 95° degrees (Target: 90° degrees).

CAUTION:

- **Check tightening angle with an angle wrench or a protractor. Do not make judgment by visual check alone.**

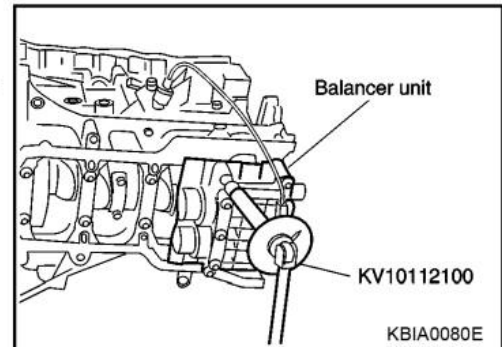
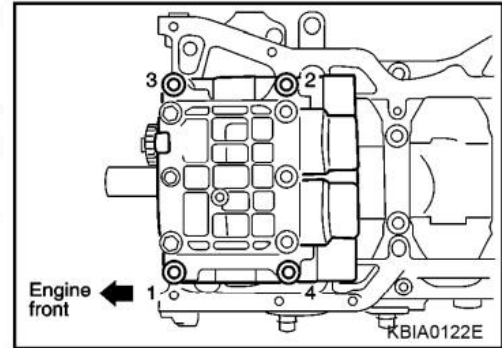

3. Install the crankshaft sprocket and timing chain for the balancer unit.

- Make sure that the crankshaft sprocket is positioned with mating marks on the block and sprocket meeting at the top.
- Install it by lining up mating marks on each sprocket and timing chain.

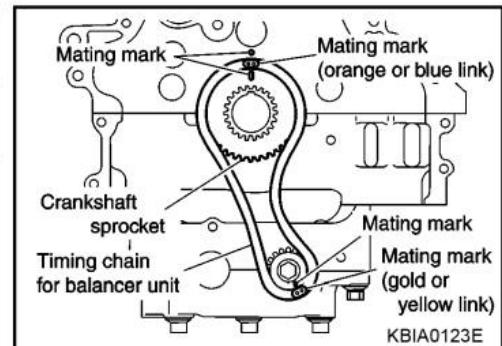

TIMING CHAIN

[QR25DE]

4. Install timing chain tensioner for balancer unit.

NOTE:

Chain guide and tensioner move freely with the caulking pin as the axle. Therefore, bolt hole position of the three points could be changed during removal. If points change, temporarily fix the two mounting bolts on the chain guide and move the tensioner to match the bolt holes.

- Be careful not to let mating marks of each sprocket and timing chain slip.
- After installation, make sure the mating marks have not slipped, then remove stopper pin and release tensioner.

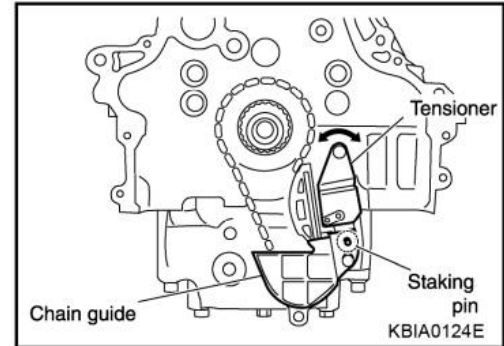

5. Install timing chain and related parts.

- Install by lining up mating marks on each sprocket and timing chain as shown.

NOTE:

Before installing chain tensioner, it is possible to change the position of mating mark on timing chain for that of each sprocket for alignment.

CAUTION:

For the above reason, after the mating marks are aligned, keep them aligned by holding them with a hand.

- Before and after installing chain tensioner, check again to make sure that mating marks have not slipped.
- After installing chain tensioner, remove stopper pin, and make sure the tensioner moves freely.
- To avoid skipped teeth, do not move crankshaft and camshaft until front cover is installed.

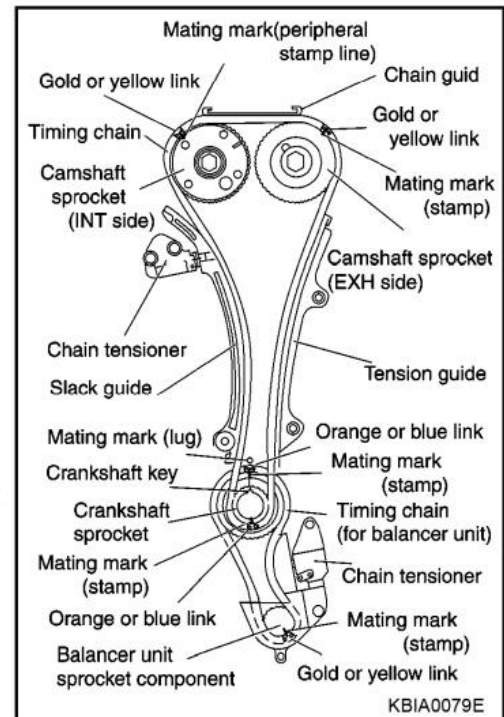

6. Install front oil seal to front cover.

- Using a drift of 56 mm (2.20 in) diameter, press oil seal in until it is flush with front end surface of front cover.

CAUTION:

- **Be careful not to cause damage to circumference of oil seal.**

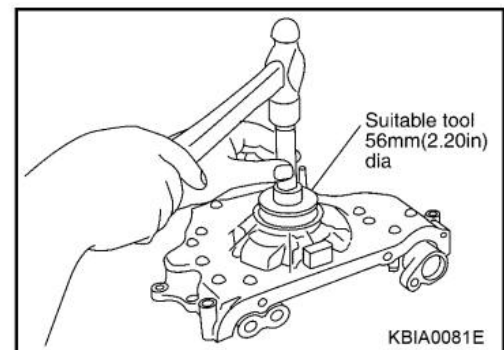

TIMING CHAIN

[QR25DE]

7. Install front cover with the following procedure:
 - a. Install O-rings to cylinder head and cylinder block.
 - b. Apply Genuine RTV Silicone Sealant or equivalent, to positions specified in the figure. Refer to [GI-36, "RECOMMENDED CHEMICAL PRODUCTS AND SEALANTS"](#).
 - c. Make sure the mating marks on the timing chain and each sprocket are still aligned. Then install the front cover.

CAUTION:

- Be careful not to damage the front oil seal during installation with the front end of the crankshaft.

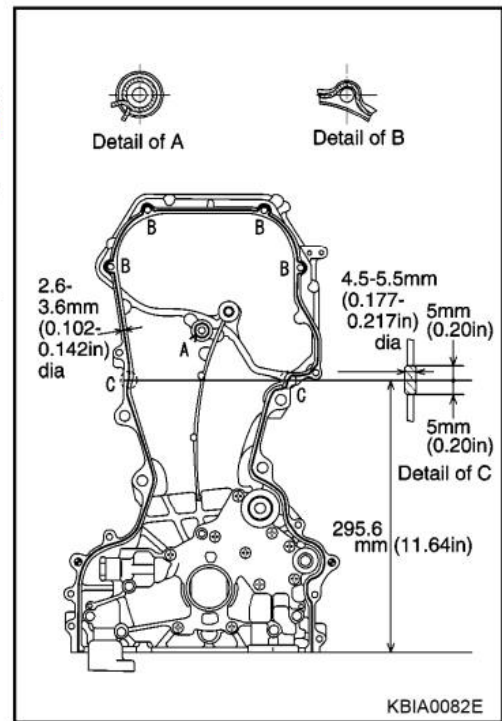

- d. Tighten mounting bolts in the numerical order shown.
- e. After all bolts are tightened, retighten them to the specified torque.

Front cover bolts : 12 - 13 N·m (1.2 - 1.4 kg·m, 9 - 10 ft·lb)

CAUTION:

Wipe off any excess sealant leaking at the surface for installing the oil pan.

8. Install the chain guide between the camshaft sprockets.

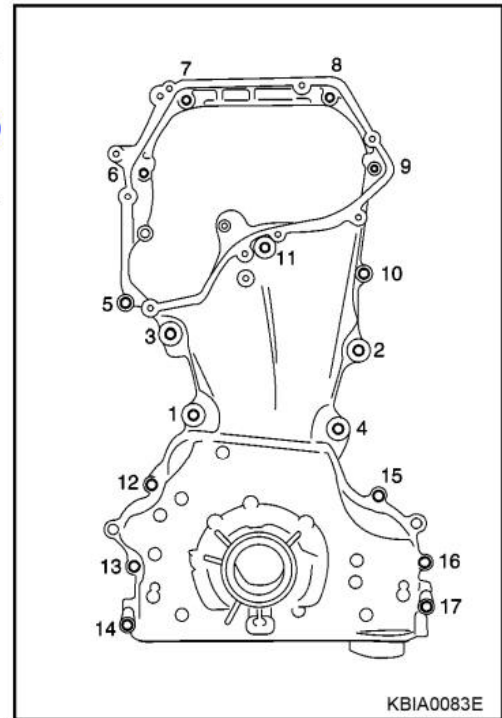

9. Install IVTC cover with the following procedure:
 - a. Install IVTC solenoid valves to IVTC cover.
 - b. Install oil rings to the intake camshaft sprocket insertion points on Intake valve timing control backside cover.
 - c. Install O-ring to front cover.

TIMING CHAIN

[QR25DE]

d. Apply RTV Silicone Sealant to the positions in the figure.

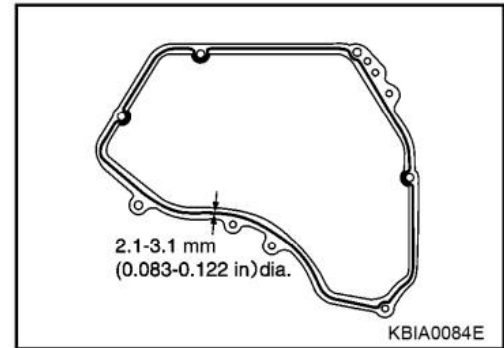

e. Tighten the mounting bolts in the numerical order as shown.

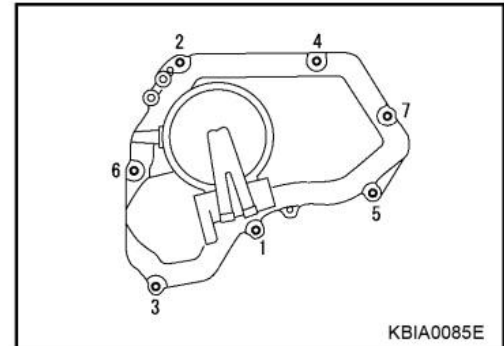

10. Insert crankshaft pulley by aligning with crankshaft key.

- Tap its center with a plastic hammer to insert.
- Do not tap the belt hook.

11. Tighten crankshaft pulley mounting bolts.

- Secure crankshaft pulley with a pulley holder to tighten the bolt.
- Perform angle tightening with the following procedure:

- Apply new engine oil to threads and seat surfaces of mounting bolts.
- Tighten to initial specifications:

Crankshaft pulley bolt initial tightening : 37.3 - 47.1 N·m (3.8 - 4.8 kg·m, 28 - 34 ft·lb)

c. Apply a paint mark on the front cover, mating with any one of six easy to recognize stamp marks on bolt flange.

d. Turn crankshaft pulley bolt another 60° to 66° degrees [Target: 60° degrees].

- Check vertical mounting angle with movement of one stamp mark.

12. Installation of the remaining parts is in reverse order of removal.

